



IEC 61196-1-326

Edition 1.0 2022-10

INTERNATIONAL STANDARD



**Coaxial communication cables –
Part 1-326: Mechanical test methods – Hanger test**





THIS PUBLICATION IS COPYRIGHT PROTECTED
Copyright © 2022 IEC, Geneva, Switzerland

All rights reserved. Unless otherwise specified, no part of this publication may be reproduced or utilized in any form or by any means, electronic or mechanical, including photocopying and microfilm, without permission in writing from either IEC or IEC's member National Committee in the country of the requester. If you have any questions about IEC copyright or have an enquiry about obtaining additional rights to this publication, please contact the address below or your local IEC member National Committee for further information.

IEC Secretariat
3, rue de Varembe
CH-1211 Geneva 20
Switzerland

Tel.: +41 22 919 02 11
info@iec.ch
www.iec.ch

About the IEC

The International Electrotechnical Commission (IEC) is the leading global organization that prepares and publishes International Standards for all electrical, electronic and related technologies.

About IEC publications

The technical content of IEC publications is kept under constant review by the IEC. Please make sure that you have the latest edition, a corrigendum or an amendment might have been published.

IEC publications search - webstore.iec.ch/advsearchform

The advanced search enables to find IEC publications by a variety of criteria (reference number, text, technical committee, ...). It also gives information on projects, replaced and withdrawn publications.

IEC Just Published - webstore.iec.ch/justpublished

Stay up to date on all new IEC publications. Just Published details all new publications released. Available online and once a month by email.

IEC Customer Service Centre - webstore.iec.ch/csc

If you wish to give us your feedback on this publication or need further assistance, please contact the Customer Service Centre: sales@iec.ch.

IEC Products & Services Portal - products.iec.ch

Discover our powerful search engine and read freely all the publications previews. With a subscription you will always have access to up to date content tailored to your needs.

Electropedia - www.electropedia.org

The world's leading online dictionary on electrotechnology, containing more than 22 300 terminological entries in English and French, with equivalent terms in 19 additional languages. Also known as the International Electrotechnical Vocabulary (IEV) online.



IEC 61196-1-326

Edition 1.0 2022-10

INTERNATIONAL STANDARD



**Coaxial communication cables –
Part 1-326: Mechanical test methods – Hanger test**

INTERNATIONAL
ELECTROTECHNICAL
COMMISSION

ICS 33.120.10

ISBN 978-2-8322-5775-3

Warning! Make sure that you obtained this publication from an authorized distributor.

CONTENTS

FOREWORD.....	3
1 Scope.....	5
2 Normative references	5
3 Terms and definitions	5
4 Test methods.....	5
4.1 General.....	5
4.2 Slippage test.....	5
4.2.1 Samples	5
4.2.2 Test method	6
4.2.3 Requirements	7
4.2.4 Report	8
4.3 Hanger compression test	8
4.3.1 General	8
4.3.2 Samples	8
4.3.3 Test method	8
4.3.4 Requirements	9
4.3.5 Report	9
4.4 Salt mist exposure	9
4.4.1 Sample	9
4.4.2 Method	9
4.4.3 Requirements	9
4.4.4 Report	9
4.5 Side loading test.....	10
4.5.1 General	10
4.5.2 Samples	10
4.5.3 Procedure.....	10
4.5.4 Test report.....	12
Figure 1 – Example of a test setup for slippage test method with one cable sample	6
Figure 2 – Example of a test setup for side load test.....	10
Figure 3 – Example of a test setup for side load test.....	11
Table 1 – Dwell times by temperature method.....	7
Table 2 – Dwell times by unknown temperature	7

INTERNATIONAL ELECTROTECHNICAL COMMISSION

COAXIAL COMMUNICATION CABLES –

Part 1-326: Mechanical test methods – Hanger test

FOREWORD

- 1) The International Electrotechnical Commission (IEC) is a worldwide organization for standardization comprising all national electrotechnical committees (IEC National Committees). The object of IEC is to promote international co-operation on all questions concerning standardization in the electrical and electronic fields. To this end and in addition to other activities, IEC publishes International Standards, Technical Specifications, Technical Reports, Publicly Available Specifications (PAS) and Guides (hereafter referred to as "IEC Publication(s)"). Their preparation is entrusted to technical committees; any IEC National Committee interested in the subject dealt with may participate in this preparatory work. International, governmental and non-governmental organizations liaising with the IEC also participate in this preparation. IEC collaborates closely with the International Organization for Standardization (ISO) in accordance with conditions determined by agreement between the two organizations.
- 2) The formal decisions or agreements of IEC on technical matters express, as nearly as possible, an international consensus of opinion on the relevant subjects since each technical committee has representation from all interested IEC National Committees.
- 3) IEC Publications have the form of recommendations for international use and are accepted by IEC National Committees in that sense. While all reasonable efforts are made to ensure that the technical content of IEC Publications is accurate, IEC cannot be held responsible for the way in which they are used or for any misinterpretation by any end user.
- 4) In order to promote international uniformity, IEC National Committees undertake to apply IEC Publications transparently to the maximum extent possible in their national and regional publications. Any divergence between any IEC Publication and the corresponding national or regional publication shall be clearly indicated in the latter.
- 5) IEC itself does not provide any attestation of conformity. Independent certification bodies provide conformity assessment services and, in some areas, access to IEC marks of conformity. IEC is not responsible for any services carried out by independent certification bodies.
- 6) All users should ensure that they have the latest edition of this publication.
- 7) No liability shall attach to IEC or its directors, employees, servants or agents including individual experts and members of its technical committees and IEC National Committees for any personal injury, property damage or other damage of any nature whatsoever, whether direct or indirect, or for costs (including legal fees) and expenses arising out of the publication, use of, or reliance upon, this IEC Publication or any other IEC Publications.
- 8) Attention is drawn to the Normative references cited in this publication. Use of the referenced publications is indispensable for the correct application of this publication.
- 9) Attention is drawn to the possibility that some of the elements of this IEC Publication may be the subject of patent rights. IEC shall not be held responsible for identifying any or all such patent rights.

IEC 61196-1-326 has been prepared by subcommittee 46A: Coaxial cables, of IEC technical committee 46: Cables, wires, waveguides, RF connectors, RF and microwave passive components and accessories. It is an International Standard.

The text of this International Standard is based on the following documents:

Draft	Report on voting
46A/1589/FDIS	46A/1602/RVD

Full information on the voting for its approval can be found in the report on voting indicated in the above table.

The language used for the development of this International Standard is English.

This document was drafted in accordance with ISO/IEC Directives, Part 2, and developed in accordance with ISO/IEC Directives, Part 1 and ISO/IEC Directives, IEC Supplement, available at www.iec.ch/members_experts/refdocs. The main document types developed by IEC are described in greater detail at www.iec.ch/standardsdev/publications.

A list of all the parts in the IEC 61196 series, published under the general title *Coaxial communication cables*, can be found on the IEC website.

The committee has decided that the contents of this document will remain unchanged until the stability date indicated on the IEC website under webstore.iec.ch in the data related to the specific document. At this date, the document will be

- reconfirmed,
- withdrawn,
- replaced by a revised edition, or
- amended.

IMPORTANT – The "colour inside" logo on the cover page of this document indicates that it contains colours which are considered to be useful for the correct understanding of its contents. Users should therefore print this document using a colour printer.

COAXIAL COMMUNICATION CABLES –

Part 1-326: Mechanical test methods – Hanger test

1 Scope

This part of IEC 61196 describes the test methods to evaluate the suitability of hangers to support a cable on an antenna tower, or on other constructions. This document also provides generic criteria to evaluate performance.

2 Normative references

The following documents are referred to in the text in such a way that some or all of their content constitutes requirements of this document. For dated references, only the edition cited applies. For undated references, the latest edition of the referenced document (including any amendments) applies.

IEC 60068-2-11, *Environmental testing – Part 2-11: Tests – Test Ka: Salt mist*

IEC 60068-2-14, *Environmental testing – Part 2-14: Tests – Test N: Change of temperature*

3 Terms and definitions

No terms and definitions are listed in this document.

ISO and IEC maintain terminological databases for use in standardization at the following addresses:

- IEC Electropedia: available at <http://www.electropedia.org/>
- ISO Online browsing platform: available at <http://www.iso.org/obp>

4 Test methods

4.1 General

This document includes different test methods to evaluate the suitability of hangers to support one or more cables. While recommended, it is not intended that all tests be carried out in all cases. The tests to be applied can be specified in the relevant specification or agreed between customer and supplier. The hanger specification shall provide the following:

- a) cable information by cable type or diameter if rigid,
- b) weight to be supported in slippage test if not cable specific.

4.2 Slippage test

4.2.1 Samples

- a) six hangers,
- b) cable length: 2 m with a tolerance of $\pm 1\%$ (alternate 0,7 m with a tolerance of $\pm 1\%$ depending on thermal chamber size constraints),
- c) three cables.

4.2.2 Test method

4.2.2.1 Initial measurements

Prior to the test, the following measurements shall be made unless otherwise specified.

- a) accessory and cable information,
- b) cable dimensions (critical),
- c) accessory dimensions (critical).

Prior to conducting the test, initial measurements shall be performed by reference against specifications.

Visually inspect the cable to make sure it is free of kinks, bends, dents, and/or other visible defects.

4.2.2.2 Procedure

Attach the cable and hangers (2 hangers per cable run spaced 3 feet (e.g. 1 m) apart) to associated hardware (tower mock-up) per manufacturer's instructions. When using the alternate DUT length, due to the thermal chamber size limitations, the space between hangers shall be 0,4 m. See Figure 1.

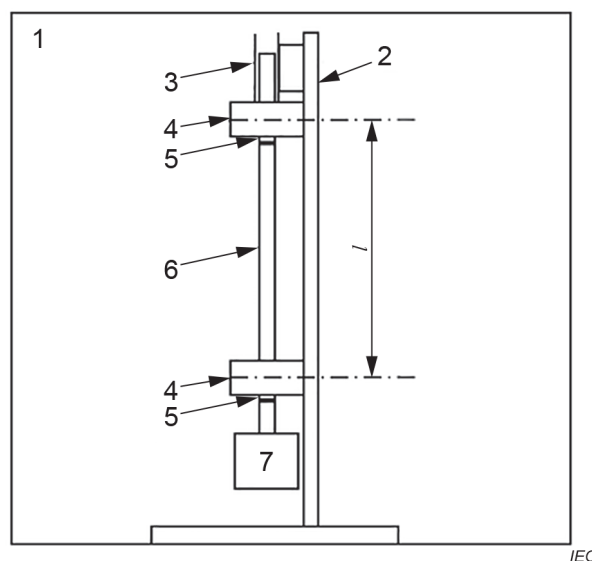

Key

- 1 thermal chamber
- 2 fixture
- 3 rigid tube over cable (one option)
- 4 hanger
- 5 mark
- 6 cable sample
- 7 weight attached to cable sample
- l spacing between hangers

Figure 1 – Example of a test setup for slippage test method with one cable sample

The cables at the top of the support shall be as straight as possible. Possible ways to accomplish this are described below.

- a) The cable assembly is maintained to within 15,2 mm of the top of the hanger, or
- b) A rigid tube is placed over the top of the cable and secured to the hanger fixture.

Place the completed assembly into the thermal chamber, attaching the specific weight. If not otherwise specified, as follows:

- 1) Weight to attach (Kg) = Cable weight/per meter (kg/m) × 2 (m); if using the alternate DUT length (0,7 m), weight to attach (Kg) = Cable weight/per meter (kg/m) × 3,3 (m).
- 2) Weight may be rounded up to the nearest whole kilogram.

Mark the location on the bottom of each hanger using a paint pen, or other indelible type marker.

Thermal cycle method shall conform to the procedure in IEC 60068-2-14, Method Nb, with dwells as defined in item a) and transition rate at 2 °C/minute. The dwell temperatures are the minimum and maximum specified operating temperatures of the cable.

- a) The dwell times should be established by the temperature method shown in Table 1 or, if unknown, the dwell time should be as shown in Table 2.

Table 1 – Dwell times by temperature method

Weight of specimen kg	Dwell time h
1,5	1
> 1,5 to ≤ 7,5	1,5
>7,5 to ≤ 14	2
> 14 to ≤ 75	3
> 75 to ≤ 140	4
> 140	8

Table 2 – Dwell times by unknown temperature

Weight of specimen/ test fixtures kg	Dwell time h	Min dwell time h
>7,5 to ≤ 75	1/2 hour after dwell temperature reached on surface of DUT	1,5
>75	1 hour after dwell temperature reached on surface of DUT	3

- b) The number of cycles should be 25.

Start the test.

At 12 cycles and at the conclusion of the test, the following points of the assembly shall be evaluated.

- a) Cable slippage: measure and record the location of each hanger relative to the previously marked location.
- b) Cable dimensions (critical): measure and record if measurable cable slippage has occurred.

4.2.3 Requirements

The cable slippage shall not exceed the cable diameter and there should be no damage to the device under test.

4.2.4 Report

The report shall contain:

- a) whether the amount of slippage was acceptable,
- b) general information:
 - 1) part number of the hanger and cable tested,
 - 2) date code,
 - 3) thermal cycle profile and number of cycles,
 - 4) weight suspended from the cable,
 - 5) calibration dates of any instrument used.
- c) results:
 - 1) initial results
 - i) cable dimensions,
 - ii) accessory dimensions,
 - iii) photos of setup,
 - 2) post results
 - i) amount of slippage,
 - ii) cable dimensional performance changes,
 - iii) photos of setup.

4.3 Hanger compression test

4.3.1 General

The hanger specification should provide the following:

- a) the tightening force required for test,
- b) cable to use for test,
- c) hanger mounting instructions.

4.3.2 Samples

- a) three hangers,
- b) three cable assemblies.

4.3.3 Test method

4.3.3.1 General

- a) The tests are done at ambient temperature.
- b) For RL and IL measurements, the DUT shall be continuously connected when placing the hanger onto the assembly.
- c) In coaxial cables where PIM is measured, the PIM will need to be measured prior to the RL and IL and after the RL and IL tests.

4.3.3.2 Procedure

The initial measurement shall be made and the equipment for IL/RL shall remain connected.

The hanger shall be placed on the cable at any convenient location and tightened to the specified requirements as applicable. The tightening torque shall be measured.

The measurements shall be made after 1 minute of installation of the hanger on the cable.

When applicable, the tightening torque shall be increased by 25 % and the test repeated to evaluate the design margin.

4.3.4 Requirements

The coaxial cable performance should not be impacted as follows:

- a) $RL \leq 1,0$ dB degradation change,
- b) $IL \leq 0,2$ dB degradation change.

4.3.5 Report

The report shall include:

- a) part number of the hanger and cable tested,
- b) date codes of parts,
- c) description of the test setup with photos,
- d) diameter of the cable,
- e) the tightening torque of the hanger if appropriate,
- f) acceptability of results
 - 1) pass or fail,
 - 2) test results,
 - 3) photos showing setup,
- g) results of increase torque if appropriate,
- h) instruments used in test along with calibration dates.

4.4 Salt mist exposure

4.4.1 Sample

Three samples of the hanger shall be subjected to this test.

The hangers shall be mounted to a simulated antenna bracket, holding a small length of cable.

4.4.2 Method

The units shall be subjected to the salt mist test of IEC 60068-2-11 for a period of 500 hours.

4.4.3 Requirements

At the conclusion of the test, there should be no obvious deterioration of the hanger visual appearance or mechanical deterioration.

4.4.4 Report

The report shall include:

- a) part number of the hanger and cable tested,
- b) date codes of parts,
- c) description of the test setup with photos
 - 1) diameter of the cable,
 - 2) tightening torque of the hanger if appropriate,
 - 3) acceptability of results,
 - i) pass or fail,
 - ii) test results,
 - iii) photos showing setup,

d) results of increase torque if appropriate.

4.5 Side loading test

4.5.1 General

- a) This test covers the ability of a hanger to withstand a wind and ice side load generated by the conditions of 200 km/h wind and 12,5 mm ice buildup.
- b) This test will cover cables of the same or smaller diameter for the same hanger.
- c) The forces applied are shown in Figure 2.

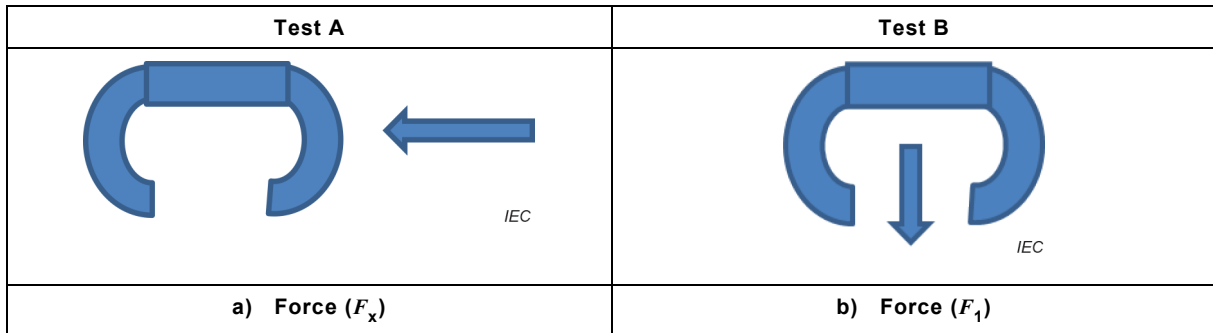

- a) For test A, a single hanger may be tested with the force adjusted for the maximum number of stacks.
- b) The mounting means for the hanger under test should simulate a typical tower mount.
- c) The forces shall be given in the relevant sectional or detail specification of the hanger.
 - 1) For test A, the force is F_x .
 - 2) For test B, the force is F_1 .
- d) A separate sample is used for tests A and B.

Figure 2 – Example of a test setup for side load test

4.5.2 Samples

- a) three hangers for each test,
- b) three cables or equivalent rod, 15 mm to 30 mm in length.

4.5.3 Procedure

- a) A single hanger will be mounted on an appropriate structure to simulate the antenna tower.
- b) A small piece of cable sufficient to attach “pull leads” to each side of the cable will be installed in the hanger. The pull leads will be used to apply the load. A small rigid rod of equal cable diameter may be used instead of the cable. For flexible cables, a rigid rod will be required.
- c) The wind load is calculated as shown in Figure 3.

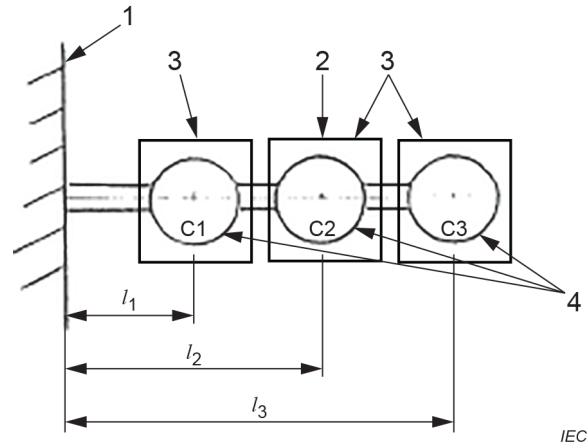
**Key**

1 tower

2 wind

3 hanger

4 cable

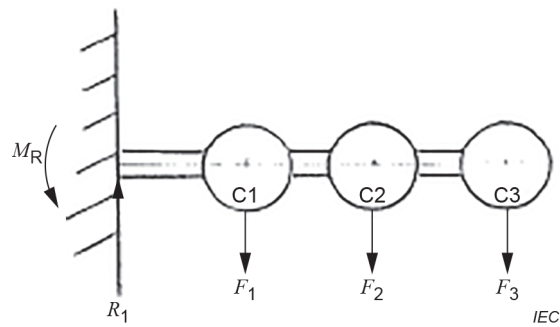
 l length between the tower and the cable center line**a) Cables shown triple stacked**

The wind creates a load (F_1 , F_2 and F_3) at each cable. This results in reactions R_1 and M_R at the tower.

The sum of the moments, M , can be expressed as:

$$M_R = F_1 l_1 + F_2 l_2 + F_3 l_3$$

Assuming that all cables have the same diameter:

$$M_R = F_1 (l_1 + l_2 + l_3)$$

b) Free-body diagram of loads

Figure 3 – Example of a test setup for side load test

4.5.4 Test report

The report shall include

- a) part number of the hanger and cable tested,
 - b) date codes of parts,
 - c) description of the test setup with photos,
 - d) the forces F_1 and F_x applied and the rate of application,
 - e) duration of dwell time of each force,
 - f) acceptability of results
 - 1) pass or fail,
 - 2) photos if applicable,
 - g) instruments used in the test with recorded calibration dates.
-

INTERNATIONAL
ELECTROTECHNICAL
COMMISSION

3, rue de Varembé
PO Box 131
CH-1211 Geneva 20
Switzerland

Tel: + 41 22 919 02 11
info@iec.ch
www.iec.ch